

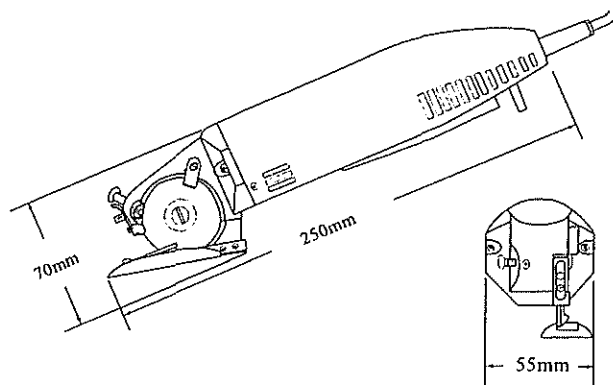

# OPERATING INSTRUCTIONS MAINTENANCE & SAFETY

## AS-100K (AS-101)



### constructive and functional characteristics:

	M.U.	AS-100K/ AS-101
Blade size	mm	Hexagonal blade 50 mm
Cutting capacity	mm	7.2
Power	w	50
Voltage	v	1Φ, 220/230/240V or 110/120V
Sharpener	-	With built in "push button" sharpener
Safety	-	With finger guard, CE
Weight	kg	1.10
Dimension(LxWxH)	mm	250x55x70

\* Model with 230v, Other Countries 100/120v according to the nameplates.

### IMPORTANT:

Save This Instruction Manual

Before Use Read This Instruction Manual

### TO OPERATE MACHINE:

- 1.The machine has to be connected to correct outlet 110V or 220V ac current.
- 2.Press (5013) on/off handle.
- 3.By doing above, the knife (1026) will start to rotate, the machine is in cutting condition. Start to cut.

### TO CHANGE KNIFE:

A faultless cut can be achieved only if knife is kept sharp. To sharpen knife, put light pressure on (1007) sharpener button. To change knife, loosen knife lock screw (1027), insert pin thru small hole in knife against (1010) sharpening stone. Use large screw driver to loosen screw.

### TO CHANGE (5005) MOTOR BRUSH:

Loosen and take out three (5010) screws, pull out motor assembly, loosen (5004), pull out brushes, inspect- replace if necessary.

### LUBRICATION:

The helix gear should be greased every six months by removing three screws, which holds (1029) knife support. Pull out helix gear assy (1031) and put lubricant grease around (1014) shaft approx. 1/3 full.

### ⚠ WARNING:

To perform any maintenance procedure, the machine must be disconnected from power source.

### ⚠ WARNING:

To avoid overheating and possible loss of power during operations, user should follow the instructions as outlined below:

- 1.This CUTTER is designed to cut fabrics only. Maximum thickness should be two(2) plys of medium weight.
- 2.NEVER cover air vents while operating CUTTER. Air vents must be kept free of lint and dirt.
- 3.MAXIMUM cutting height is 5/16"(8mm.) and may be less for heavy or tough materials.
- 4.NEVER compress fabric to fit CUTTER mouth.
- 5.This CUTTER is designed to cut in intervals. NEVER

operate CUTTER on maximum fabric height for intervals longer than one(1) minute without releasing switch. NEVER secure switch in "on" position while cutting such as with adhesive tape.

6.Insert material into CUTTER mouth only AFTER blade has begun rotating.

### MAINTENANCE:

To maintain excellent cutting performance from your AS-100K MINI CUTTER, the following routine maintenance procedures should be performed:

- 1.Replace knife when worn down to within approximately 1 5/8"(42mm). NOTE: When this CUTTER is used with a worn knife, the cutting edge will make contact farther back on the carbide counter cutting blade. This will cause a loss of the scissor action, whereby almost all cutting action is lost.
2. SHARPENING KNIFE: Lightly press the sharpener cap (1007) just enough for sharpening stone(1010) to grind the rotating knife. Don't press too hard because it can burn the knife. Always keep knife sharp and clean for accurate cutting.
- 3.CARBON BRUSHES(5005): Check at least once a month. To change, use a phillips screwdriver to remove the three screws(5010) from the frame(5011). Slide off the frame, remove the brass screw(5004) from the exposed motor, remove and replace worn brushes.
- 4.OSCILLATING OILER(1017): Saturate oil felt(1016) TWICE DAILY, with 10 weight oil through the oiler housing hole.
- 5.GEAR ASSEMBLY (1024,1025,1029): DAILY CLEANING
  - A. Pull oiler housing(1017) slightly outward, swing it up and over the stop pin away from the knife.
  - B. Insert an Allen key or any other similar tool into the hole in the knife.
  - C. Remove knife lock screw(1027) with screwdriver or coin.
  - D. Tip CUTTER over and blade should drop off easily.
  - E. To clean gear surface, use cleaning fluid(ex.WD40) brush gear surface clean of all lint, fibers, etc.

2015.03 X 2000

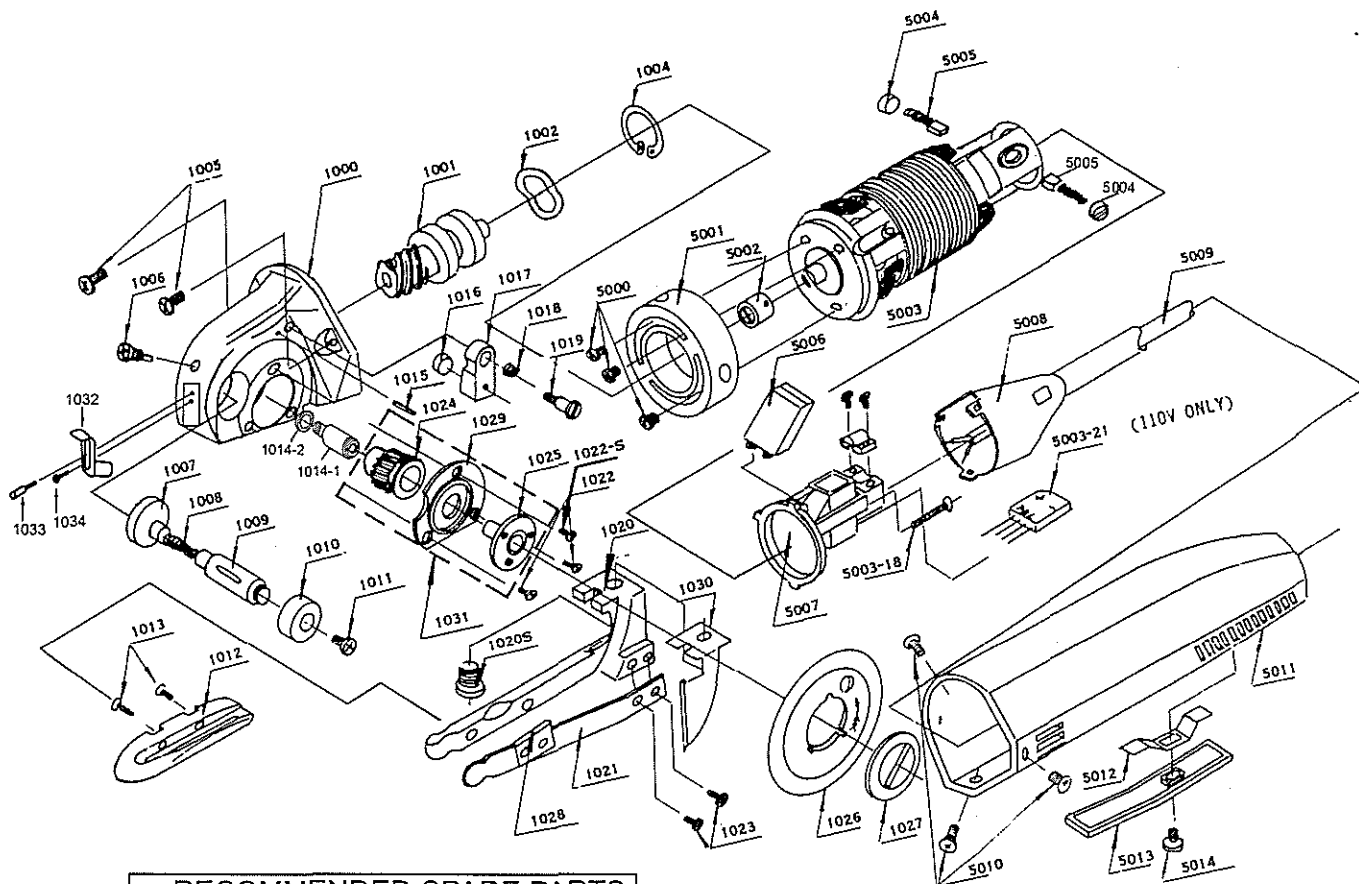

**RECOMMENDED SPARE PARTS**  
 1026 - KNIFE  
 5002 - SHAFT COUPLING  
 5005 - MOTOR BRUSHES

**MINI-SHEAR PARTS LIST**

<u>PART NO.</u>	<u>QTY.</u>	<u>DESCRIPTION</u>
AS-1000	1	GEAR CASE
AS-1001	1	WORM GEAR & BEARING ASSY
AS-1002	1	UNDULATED WASHER
AS-1004	1	RETAINING RING
AS-1005	2	GEAR CASE TO BODY SCREW
AS-1006	1	SHAPRENER SHAFTSCREW
AS-1007	1	SHARPENER CAP
AS-1008	1	SHARPENER SPRING
AS-1009	1	SHARPENER SHAFT
AS-1010	1	SHARPENER STONE
AS-1011	1	STONE SCREW
AS-1012	1	SHOE
AS-1013	2	SHOE SCREW
AS-1014-1	1	SCREW
AS-1014-2	1	WASHER
AS-1015	1	OILER SUPPORT PIN
AS-1016	1	OILER FELT
AS-1017	1	OILER HOUSING
AS-1018	1	OILER SPRING
AS-1019	1	OILER SCREW
AS-1020	1	LEG
AS-1020S	1	LEG SCREW
AS-1021/28	1	CUTTING BLADE W CARBIDE
AS-1022	2	KNIFE SUPPORT TO CASE SCREW
AS-1022S	1	KNIFE SUPPORT SCREW
AS-1023	2	CUTTING BLADE SCREW

<u>PART NO.</u>	<u>QTY.</u>	<u>DESCRIPTION</u>
AS-1024	1	HELIX GEAR
AS-1025	1	HELIX GEAR SUPPORT
AS-1026	1	HEXAGONAL KNIFE
AS-1027	1	KNIFE LOCK SCREW
AS-1029	1	KNIFE SUPPORT
AS-1030	1	TEACHER LASH
AS-1031	1	HELIX GEAR ASSY
AS-1032	1	KINFE GUARD
AS-1033	1	ADJUST SCREW
AS-1034	1	FIXED SCREW
AS-5000	3	DISC SCREW
AS-5001	1	DISC
AS-5002	1	SHAFT COUPLING
AS-5003	1	MOTOR ASSY (110V or 220V)
AS-5004	2	MOTOR BRUSH SCREW
AS-5005	2	MOTOR BRUSH
AS-5006	1	MICRO SWITCH
AS-5007	1	MICRO SWITCH HOUSING
AS-5008	1	SHEATH
AS-5009	1	POWER SUPPLY CABLE
AS-5010	3	HOUSING MOUNTING SCREW
AS-5011	1	HOUSING
AS-5012	1	ON-OFF HANDLE SPRING
AS-5013	1	ON-OFF HANDLE
AS-5014	1	ON-OFF HANDLE SCREW
AS-5003-18	2	MICRO SWITCH HOUSING SCREW
AS-5003-21	1	BRIDGE RECTIFIER